

GE1

2-WAY HIGH PRESSURE BALL VALVES

Edition. 21.0

CS Carbon Steel

- Type: ball valve 2 way
- Sizes: from DN6 up to DN13
- Ends: BSP-NPT-SAE
- Pressure: up to PN500
- Temp range: from -20°C to +100°C

STANDARD COMPOSITION OF VALVE

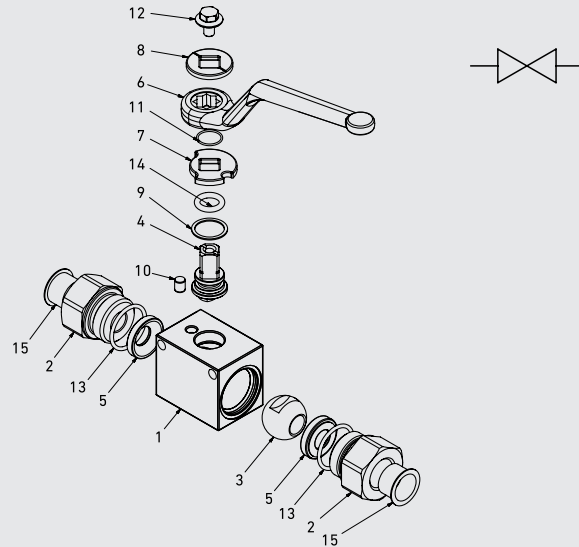

POS	DESCRIPTION	Q.TY	CS Carbon Steel MATERIAL
1	Body	1	1,0737
2	Adapter	2	1,0737
3	Ball	1	1,0737
4	Stem	1	1,0737
5	Ball seat	2	POM
6	Handle	1	ZINC
7	Washer	1	1,0116
8	Washer	1	1,0116
9	Stem ring	1	POM
10	Pin	1	1,0737
11	Seeger	1	1,4301
12	Adapter o-ring	2	NBR
13	Stem o-ring	1	NBR
14	Screw	1	Din 6921 8.8
15	Caps	2	PVC



SMALLER DESIGN

CODE DESCRIPTION STRUCTURE

GE1 G 1/4 DN6 1 1 1 1 A B

Type and way of valve

GE1 2-way

Ends

GAS DIN/	NPT ANSI	SAE
ISO 228	/ASME	J1926-1
BSP	B1.20.1	

G 1/4	N 1/4	SAE4
G 3/8	N 3/8	SAE6
G 1/2	N 1/2	SAE8

Size

from DN6 to DN13

Body Material

● 1 = 1,0737

Adapter material

● 1 = 1,0737

Stem material

● 1 = 1,0737 4 = 1,4404*

Ball Material

● 1 = 1,0737 4 = 1,4404*

Seat material

A = POM

Seal material

B = NBR

***On request**

- Reduced bore
- Special threads
- Pressure class up to PN50 MPa
- Pneumatic and electrical actuator
- Security block
- Locking device

For further special requests please consult our technical/commercial service.

SMALLER DESIGN

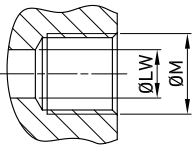
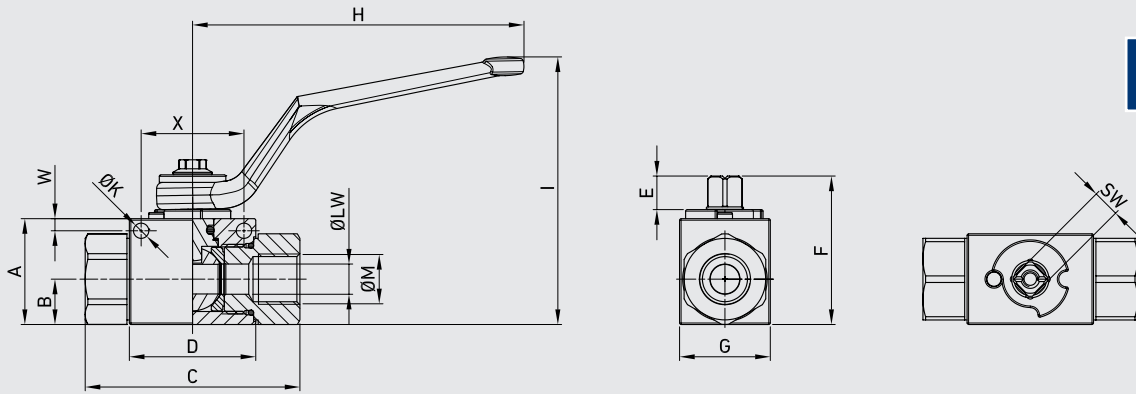

GE1 DIN/ISO 228 BSP

CS
Carbon Steel
ITEM CODE
FIXING HOLES INCLUDED

TYPE	DN	PN	A	B	C	D	E	F	G	H	I	ØM	ØK	W	X	SW	ØLW	WEIGHT
GE1 G 1/4	6	MPa 50	mm 33	14,3	69	39,4	11,1	47,25	26	110	87	G 1/4	5,10	4	34	9	6	kg 0,378
		Psi 7250	inch 1,30	0,56	2,72	1,55	0,44	1,86	1,02	4,33	3,43		0,20	0,16	1,34	0,35	0,24	lb 0,83
GE1 G 3/8	10	MPa 50	mm 35	15	71	41,8	11,1	49,25	30	110	89	G 3/8	5,1	4	34	9	10	kg 0,467
		Psi 7250	inch 1,38	0,59	2,80	1,65	0,44	1,94	1,18	4,33	3,50		0,20	0,16	1,34	0,35	0,39	lb 1,03
GE1 G 1/2	13	MPa 50	mm 40	18,3	83	44,4	11,1	54,25	35	110	94	G 1/2	5,1	4	36	9	13	kg 0,635
		Psi 7250	inch 1,57	0,72	3,27	1,75	0,44	2,14	1,38	4,33	3,70		0,20	0,16	1,42	0,35	0,51	lb 1,40

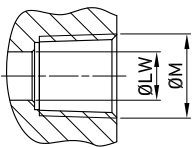

GE1 ANSI/ASME B1.20.1 NPT

CS
Carbon Steel
ITEM CODE
FIXING HOLES INCLUDED

TYPE	DN	PN	A	B	C	D	E	F	G	H	I	ØM	ØK	W	X	SW	ØLW	WEIGHT
GE1 N 1/4	6	MPa 50	mm 33	14,3	69	39,4	11,1	47,25	26	110	87	N 1/4	5,10	4	34	9	6	kg 0,378
		Psi 7250	inch 1,30	0,56	2,72	1,55	0,44	1,86	1,02	4,33	3,43		0,20	0,16	1,34	0,35	0,24	lb 0,83
GE1 N 3/8	10	MPa 50	mm 35	15	71	41,8	11,1	49,25	30	110	89	N 3/8	5,1	4	34	9	10	kg 0,467
		Psi 7250	inch 1,38	0,59	2,80	1,65	0,44	1,94	1,18	4,33	3,50		0,20	0,16	1,34	0,35	0,39	lb 1,03
GE1 N 1/2	13	MPa 50	mm 40	18,3	83	44,4	11,1	54,25	35	110	94	N 1/2	5,1	4	36	9	13	kg 0,635
		Psi 7250	inch 1,57	0,72	3,27	1,75	0,44	2,14	1,38	4,33	3,70		0,20	0,16	1,42	0,35	0,51	lb 1,40

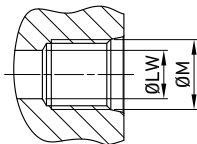
GE1 SAE J1926-1

																				CS Carbon Steel	
TYPE	DN	PN		A	B	C	D	E	F	G	H	I	ØM	ØK	W	X	SW	ØLW	WEIGHT	ITEM CODE	
GE1 SAE4	6	MPa	50	mm	33	14,3	69	39,4	11,1	47,25	26	110	87	7/16	5,10	4	34	9	6	kg 0,378	GE1EEE05011A000
		Psi	7250	inch	1,30	0,56	2,72	1,55	0,44	1,86	1,02	4,33	3,43	UNF	0,20	0,16	1,34	0,35	0,24	lb 0,83	
GE1 SAE6	10	MPa	50	mm	35	15	71	41,8	11,1	49,25	30	110	89	9/16	5,1	4	34	9	10	kg 0,467	GE1EEE15011A000
		Psi	7250	inch	1,38	0,59	2,80	1,65	0,44	1,94	1,18	4,33	3,50	UNF	0,20	0,16	1,34	0,35	0,39	lb 1,03	
GE1 SAE8	13	MPa	50	mm	40	18,3	83	44,4	11,1	54,25	35	110	94	3/4	5,1	4	36	9	13	kg 0,635	GE1EEE25011A000
		Psi	7250	inch	1,57	0,72	3,27	1,75	0,44	2,14	1,38	4,33	3,70	UNF	0,20	0,16	1,42	0,35	0,51	lb 1,40	

**FIXING HOLES
INCLUDED**